

# INSTRUCTION MANUAL



This manual **MUST** be given to the user of the product. **BEFORE** using this product, read this manual and save it for future reference.

The informations given in this manual are non-contractual and subject to change without notice.

**Non-contractual pictures.**

# Joëlette *and* Co

by Ferriol-Matrat

www.joeletteandco.com

**INTRODUCTION** .....

**USABILITY** .....

**WARRANTY** .....

**JOËLETTE KID** .....

**HOW TO OPERATE A JOËLETTE KID** .....

**GENERAL INFORMATION**.....

The team.....

The guide .....

The passenger .....

**SPECIFIC TECHNICAL HANDLING**.....

Going downwards .....

Difficult trails .....

Curves.....

Cross slopes .....

**INSTALLATION OF THE CHILD ON THE JOËLETTE KID** .....

Transfer.....

**JOËLETTE KID WITH INTERFACE FOR SEAT CORSET**

Exploded view of the interface for seat corset.....

Installation of the interface for seat corset.....

Limit dimensions of the base of the seat corset .....

Security instructions.....

**SECURITY INSTRUCTIONS** .....

Choice of trails .....

Comfort .....

The team.....

Preparing the hike.....

Insurance .....

«Rucksack» .....

During the hike .....



Exploded view of the chassis of the joëlette kid .....

Exploded view of the seat of the joëlette kid .....

**OPTIONS** .....

**MAINTENANCE** .....

**MAINTENANCE** .....

**CLEANING** .....

**DISINFECTION** .....

**INSPECTION CHECKS** .....

**LONG-TERM STORAGE** .....

**AFTER USE** .....

**DISPOSAL** .....

**TECHNICAL DATA** .....

**FOLDING/UNFOLDING THE JOËLETTE KID** .....

**EQUIP THE JOËLETTE KID WITH HEADREST (OPTION)** .....

**EQUIP THE JOËLETTE KID WITH FRONT ARMS (OPTION)** .....

**SHOCK ABSORBER ADJUSTMENT** .....

**PLACING THE JOËLETTE KID IN THE STORAGE BAGS (OPTION)** .....

**CONTACT** .....

# INTRODUCTION

This user manual contains important information about the handling of the Joëlette Kid. In order to ensure safety when using the product, read the user manual carefully and follow the safety instructions.

If you find the font size in the print version of the user manual is difficult to read, you can download the pdf from the website [www.joëletteandco.com](http://www.joëletteandco.com). The pdf can then be scaled on screen to a font size that is more comfortable for you.

USE ONLY FOR LEISURE ACTIVITIES

# USABILITY

Only use the Joëlette Kid if it is in perfect working order. Otherwise, you might put yourself and others at risk. The following list does not claim to be exhaustive. It is only intended to show some of the situations that could affect the usability of your Joëlette Kid.

**You should immediately stop using the Joëlette Kid if its usability is restricted due to :**

- Damage to the braking system
- Damage to the seat locking system (indexing finger)
- Damage to the frame locking system
- Insufficient tire pressure
- Damage to the headrest or the front arms (options)
- Damage to the footrest
- Damage to the holding system
- Cables that are damaged, kinked, pinched or have come loose from the fixation
- Missing safety pins
- Unusual sounds developing or occurring
- Damaged kickstand

# WARRANTY

The Joëlette Kid comes with a 2 years warranty. The Joëlette Kid must be used in strict accordance with the intended use, maintenance and service requirements as set out in this document.

**Risk of accident and loss of warranty if maintenance is insufficient (page 20).**

For reasons of safety and in order to avoid accidents which result from unnoticed wear, it is important that the Joëlette Kid undergoes a multiannual inspection and minimum once every year under normal operating conditions. Under regular operating conditions, it would be expedient to carry out intermediate checks on the brakes, accessories and running gear.

# JOËLETTE KID

The Joëlette Kid is an all-terrain chair that enables practicing hike, running and trekking for mobility-challenged people, with the help of a guide.

It is intended for children from **9 months old** and whose weight is less than **25 kilograms**. The child must be able to **hold his head, his back** and to **stay in the sitting position**.

Thanks to its two single-track wheels and its suspension system, the Joëlette Kid goes where no wheelchair can : tracks, trails, off-trails... !

A handle enables the guide to drive easily the Joëlette Kid since the weight of the passenger rests on the wheel.



From a simple walk to a very sporty hike, including running, trails and marathons, the Joëlette Kid adapts to physical capacities and driving of each groups of hikers and runners in Joëlette Kid.

The pair of front arms, in option, enables you to access the difficult tracks, thanks to an other guide in the front.

This user manual contains important information about the handling and the usability of the Joëlette Kid. In order to ensure safety when using the product, read the user manual carefully and follow the safety instructions.

Damages and errors caused by non-observance of the user manual or as a result of incorrect maintenance are excluded from all guarantees. Do not attempt to perform any work or manipulations that are not described.

The use of the Joëlette Kid is the sole responsibility of the guide(s).

## HOW TO OPERATE A JOËLETTE KID

In order to make sure that the passenger is safe, the guide should be in a good physical condition.

However, you needn't be a «professional» sportsman to operate it. The Joëlette Kid can also be used for peaceful strolls and walks on easier paths.

Operating a Joëlette Kid requires somme technical skills and a little training in the beginning. For this reason,

we suggest that you start using the Joëlette Kid on easy terrains and then you can progressively increase the degree of difficulty.

## GENERAL TECHNIQUES OF DRIVING

### THE TEAM



Only one guide is necessary to handle the Joëlette Kid. Additional persons can help according to the difficulty of the walk and their driving experience.

### THE GUIDE

The guide ensures the balance of the Joëlette Kid. He makes sure the seat is horizontally balanced with a slight decline to the back. This position is very comfortable for the passenger and shows that the Joëlette Kid is well balanced.

Once the balance is established, the guide adjusts the back handle to the height that is the most comfortable for him.

The guide is also responsible for the itinerary. He observes the terrain and decides which way to go. He pays attention to all obstacles and tries to avoid them. When he can't, he has to lean on the back handle to slightly raise the front wheel.

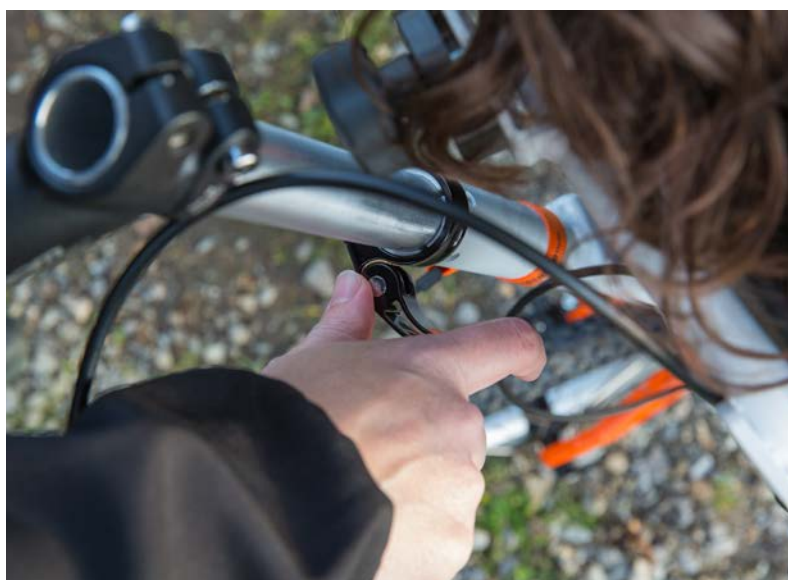

### Adjusting the back handle when stationary :

When the kickstand is open, adjust the handlebar, to operate comfortably the Joëlette Kid.

If the terrain changes, the pilote has the possibility to adjust the height of the handlebar.

**Warning :** To adjust the handlebar, you must always be stopped. If you walk at the same time, there would be risks of tipping forwards of the Joëlette Kid and/or the tube of the back handlebar could come out.

## THE PASSENGER



He has to tell the guide when he feels a lack of balance during the trip. Without balance, the passenger is not at ease which should be corrected immediately by the guide.

It's not self-evident for a disabled child to agree using the Joëlette Kid since he gives up his autonomy which he has in a usual wheelchair. His security and mobility entirely depends on the guide. The shock-absorber and the specific wheels reduce vibrations and shocks to ensure the best comfort.



### Start and stop

**The passenger must always wear a helmet on the Joëlette Kid.**

When the passenger is comfortably installed and secured, move to the side of the Joëlette Kid and hold the backrest to close and open the kickstand.

At the end of the hike, hold the backrest and move to the side to open the kickstand.

You have to constantly be careful and stay near the passenger, even when the kickstand is open, until he is not on the Joëlette Kid anymore. The kickstand is only an assistance in maintaining the Joëlette Kid, it doesn't



avoid any risks of tipping over of the Joëlette Kid.

### **Joëlette Kid's holding**

Before any walks, lock the plastron.

Adjust the height of the footrest with the clamping handle on the right side.

Position the footrest according to the child's morphology. You can change the inclination using the roller.

Adjust the headrest (in option) at the right height (at the passenger's ears), thanks to the two rollers. A good positioning of the headrest avoids an hyper-



extension of the neck.



Adjust the tilt of the backrest with the two rollers on the sides.





## SPECIFIC TECHNICAL HANDLING

### GOING DOWNWARDS

In case of descent, the guide uses the brake handle and pays special attention to the balance of the Joëlette Kid, to avoid any risk to fall over :

- He operates the brake very smoothly avoiding all abrupt operations
- He keeps his hands on the handle, at the height of

his waist.

### IN DIFFICULT TRAILS

In case of stronger slopes or important steps :

- A second guide is necessary, he has to communicate with the back guide
- In case of rough terrains, **the front arms option is mandatory**
- Be careful not to grab the foot of the passenger
- If you have to carry the Joëlette Kid, with the front arms, the back and the front guide respectively grasp the handle and the front arms, as close as possible to the passenger to reduce the scope, in order to reduce the pressure on the removable parts of the front arms.
- It is important to have stable supports to ensure your safety and the passenger's.

If the passenger fears shocks, don't let the Joëlette Kid fall back suddenly after passing over an obstacle or stairs. Amortize the movement by slightly holding back the Joëlette Kid with the front arms and the back handle.

### IN CURVES

The Joëlette Kid has fixed wheels. In curves, you have to lean on the back handle, to slightly raise the front wheel. **But keep your eyes peeled.**

## IN CROSS SLOPES

In cross slopes, the seat of the Joëlette Kid must be horizontal so the weight of the passenger lean on the wheels. The front arms option is highly recommended.

**There are the basic information concerning the Joëlette Kid.** Now, it's up to you to try the Joëlette Kid, beginning with easy terrains and then progressively find more difficult paths.

Keep in mind that the child's comfort and security are the main focus of all activities with the Joëlette Kid !



## INSTALLATION OF THE CHILD ON THE JOËLETTE KID

### TRANSFER

To open the kickstand, make sure you are on a flat ground. Install the child until the best position is reached. The plastron must be curled. Always hold the Joëlette Kid with one hand until you reach your guide position.

Be careful and always hold the Joëlette Kid when you close/open the kickstand.

Make sure the Joëlette Kid is stabilized.

Always remember to take it easy when you install the child. Make sure your tranfert technique is appropriate for the di-

sabled passenger. Ask him : he is the one who knows better his disability and will be able to tell you what kind of help he needs.

## JOËLETTE KID WITH THE INTERFACE FOR SEAT CORSET

The interface adapts to all types of seat corset, after a few minors modifications that your ortho-prosthetist can do. Respect the following security rules to make sure that it is in its good position. For the hike, your seat corset must be equipped with reinforcements which firmly fix it to the base (see on the photo). Ask your orthoprosthesis for more information.



## EXPLODED VIEW OF THE INTERFACE FOR SEAT CORSET

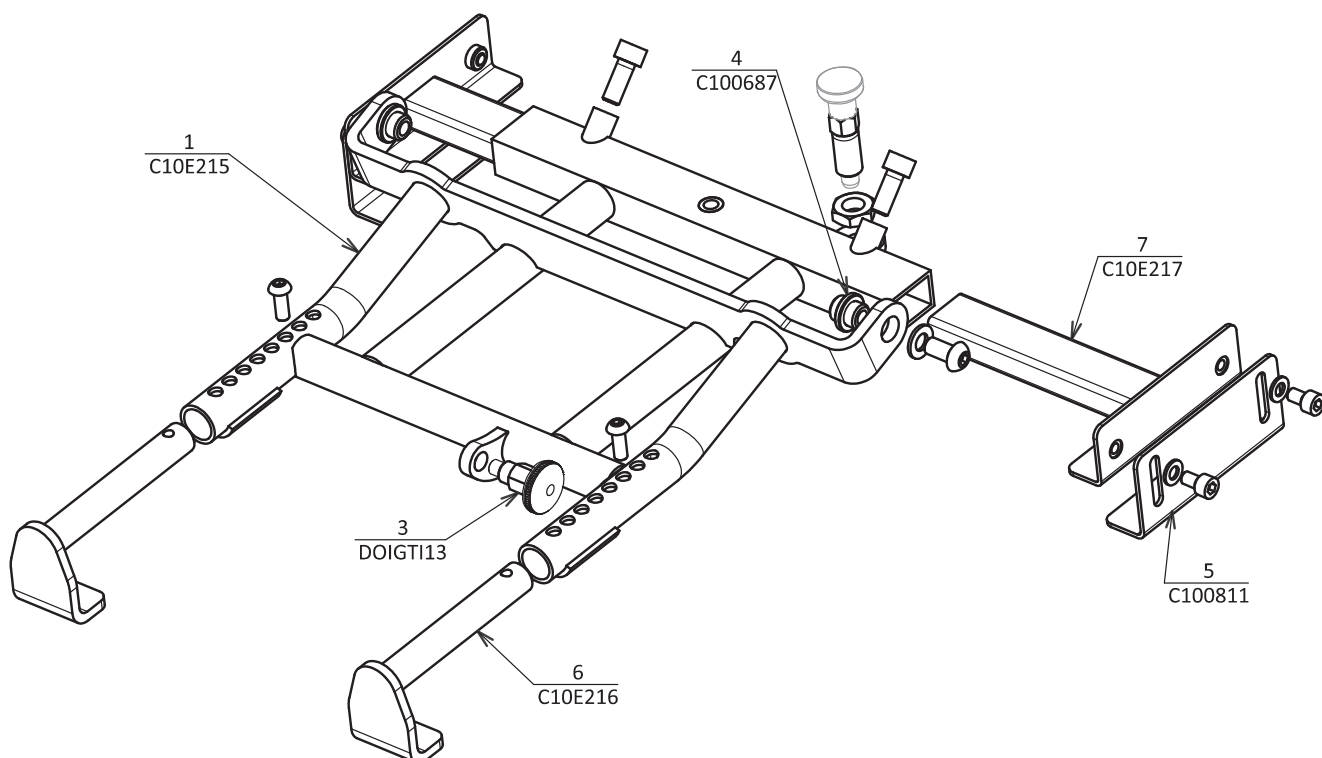
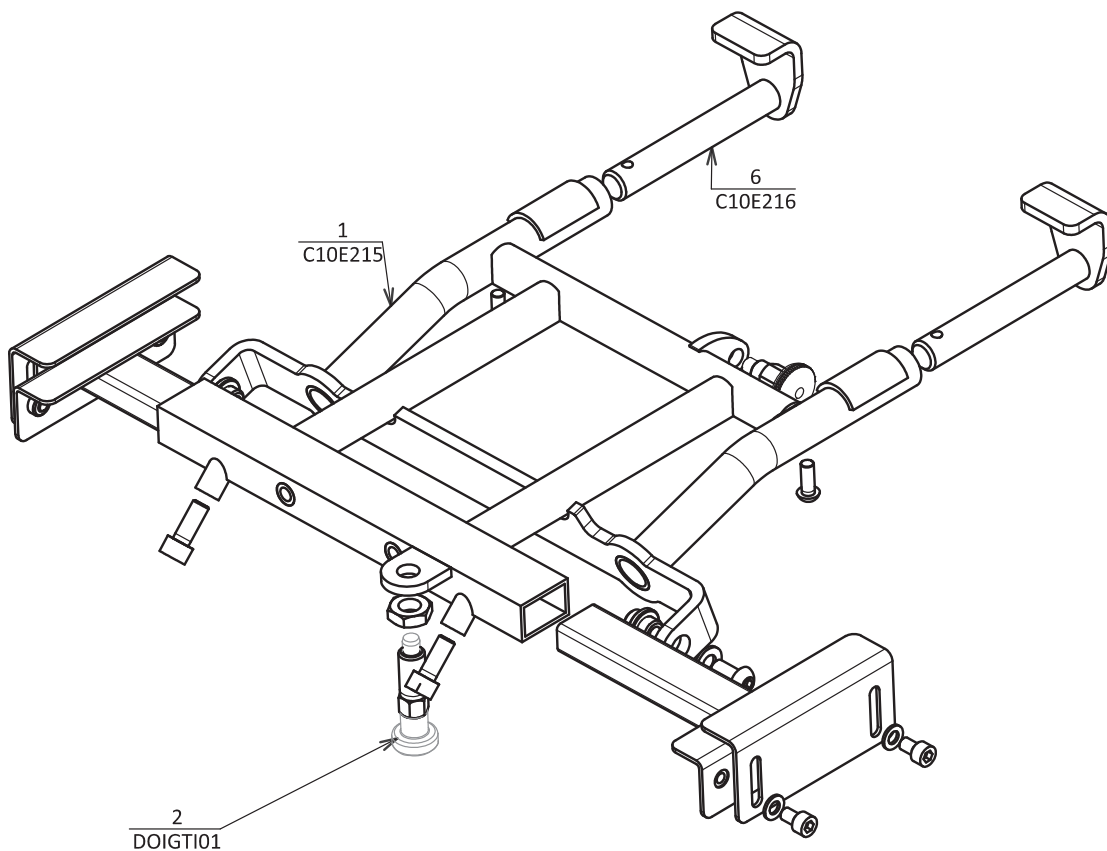

# INSTALLATION OF THE INTERFACE FOR SEAT CORSET

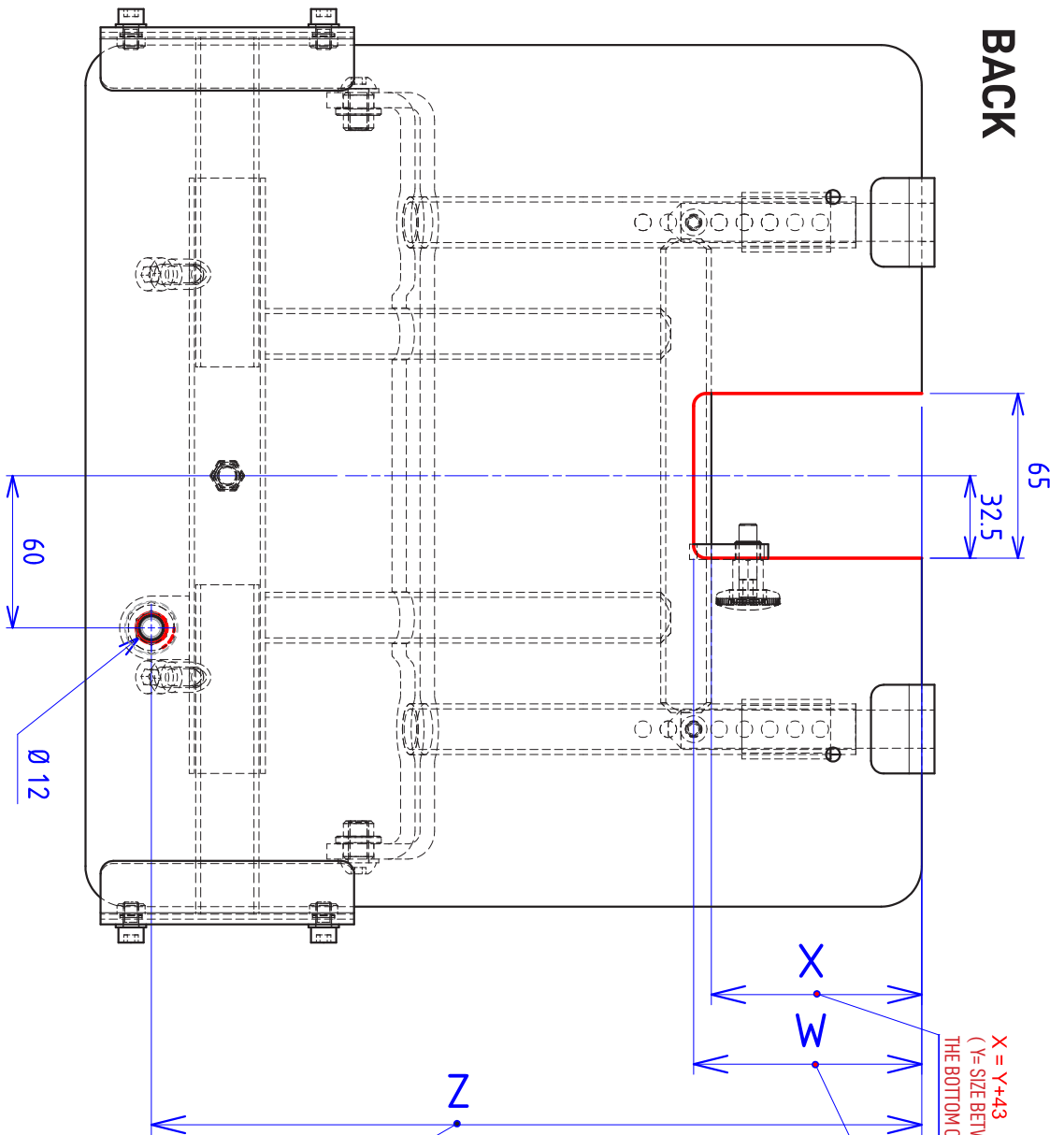

**BACK**

**X = Y+43**  
 (Y = SIZE BETWEEN THE BACK OF THE BASE AND THE BOTTOM OF THE SEAT CORSET (FIG. 1))

**W = Y+50**

1. START BY ADJUSTING DIMENSION X (MAKING SURE THAT THE BASE RESTS ON THE BACK STOPS WHICH HAVE 8 POSSIBLE POSITIONS). IF NECESSARY YOU CAN REDUCE X TO FALL ON ONE OF THE STOP POSITIONS.
2. MACHINING THE REAR RESERVE THANKS TO THE 65 AND W DIMENSIONS
3. TRANSFER THE Z AND 60 MM DIMENSIONS
4. DRILL A 12-DIAMETER HOLE IN THE RIGHT PLACE
5. GLUE THE SUPPLIED ZINC-PLATED SLEEVE INTO THE HOLE (CHAMFERED EDGE UNDERNEATH)

**Z = 280MM, WHEN THE STOPS ARE FULLY RETRACTED = 350MM, WHEN THE STOPS ARE EXTENDED TO MAXIMUM. (10MM MORE BETWEEN EACH STOP POSITION)**

**Fig. 1**

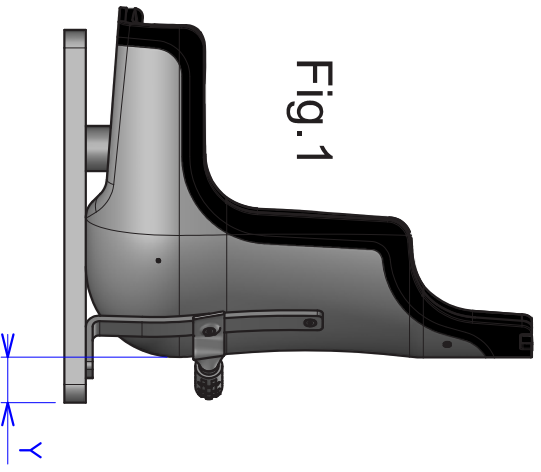

## LIMIT DIMENSIONS OF THE BASE OF THE SEAT CORSET

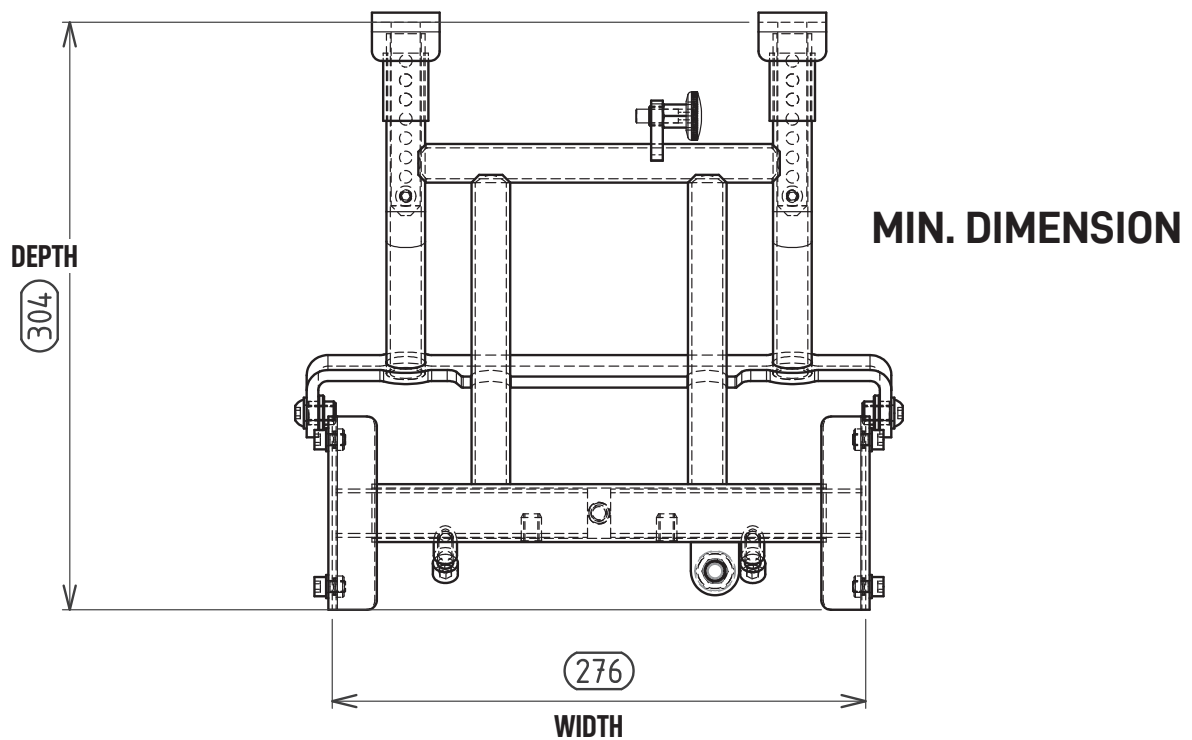
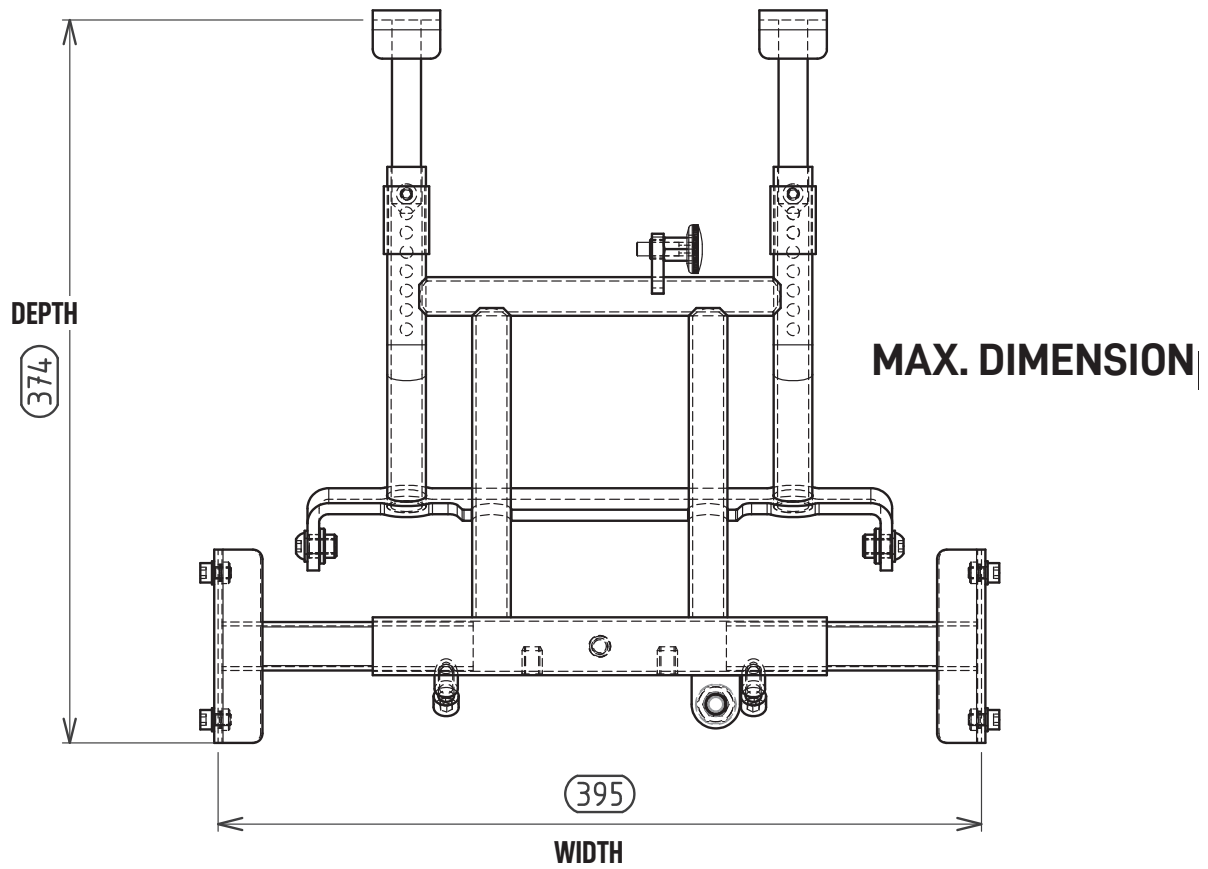

## SECURITY INSTRUCTIONS

WHEN ADAPTING THE SEAT CORSET BASE, IT IS VERY IMPORTANT TO REDUCE THE DIMENSION X TO A MINIMUM, IN ORDER TO POSITION THE CENTRE OF GRAVITY AT THE MAXIMUM ON THE REAR WHEEL. IT IS THEREFORE NECESSARY TO ADAPT THE MACHINING OF THE BASE TO OBTAIN THIS RESULT.

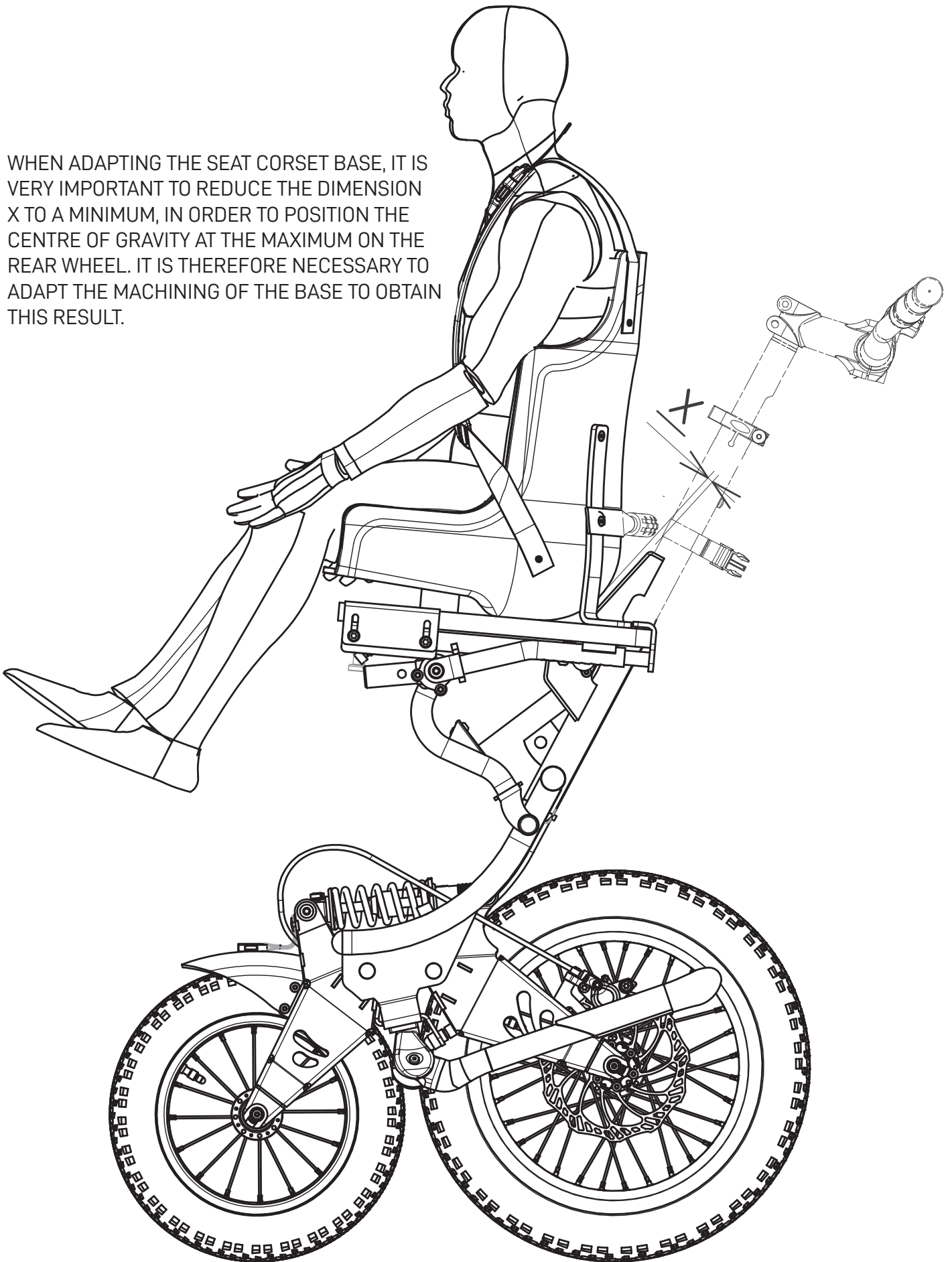

Your seat-corset must be pre-installed before the transfer. The security rules must be carefully respected.

## **SECURITY INSTRUCTIONS**

### **CHOICE OF TRAILS**

Before starting your hike, you have to check whether the itinerary is adapted to the Joëlette Kid and the team. As a matter of fact, obstacles which are easily surmountable for a common hiker, may become technically difficult for the Joëlette Kid.

However, don't think that the only constructed trails are convenient. On the contrary, most paths are accessible with the Joëlette Kid !

The best way to find out whether the Joëlette Kid is adapted is to use a mountain bike on the trail. The Joëlette passes wherever a mountain bike can pass. Difficult trails with stones, tree trunks roots just demand a higher technical competence and physical fitness.

Don't overestimate your abilities : a difficult hike or trail always requires a front guide who steers with the front arms.

### **COMFORT**

The passenger's comfort is the most important. From the start of your hike, make sure the passenger is in the best position on the Joëlette Kid by :

- adjusting the footrest and the headrest,
- making sure the clothes of the passenger are well-positioned (during the transfer they might have moved),
- pay attention to the injury risks if an element (body of the passenger, clothes...) comes in contact with moving pieces.

### **THE TEAM**

The team is composed of at least one guide who is physically able to operate the Joëlette Kid.

Don't underestimate that you need a certain level of fitness and technical skills.

### **PREPARING THE HIKE**

- Check out the itinerary beforehand.
- Choose the itinerary according to your physical capacity and technical skills.
- Check whether the Joëlette Kid is in good state, especially in a mechanical way.
- Check the meteorological conditions beforehand. Don't use the Joëlette Kid during thunderstorms. The metal construction may cause a bolt of lightning. Please also note that a path may become extremely difficult during times of rain.
- Inform your entourage about the itinerary.

- Take the front arms on hike on rough terrains.

## **INSURANCE**

Each guide must have a liability insurance to handle the Joëlette Kid. The use of the Joëlette Kid usually does not require a specific insurance but must be declared to your insurance company.

It is your responsibility to check with you insurance company, if a specific insurance is necessary in your country for the use of the Joëlette Kid.

## **«RUCKSACK»**

- Items which are in general useful during the hikes (cards, first aid kit, survival blanket, torch, water and provisions, cellphone etc.).
- Cellphone to call for help in case of an emergency (european emergency phone number 112)
- Repair kit, exchange harness etc. for the Joëlette Kid (repair kit for puncture, alternative tube, ...), small troubleshooting equipment (straps, tighteners...).
- For the passenger, who can be sensible to low temperature : warm clothing (gloves, hat,...) and a cold weather cover, if necessary. In case of bad weather conditions, take a rain protection, to protect the passenger and the Joëlette Kid's equipments.

## **DURING THE HIKE**

- A mountain bike helmet for the passenger.
- Adapted footwear for the guide.
- Make sure that the front arms are well fixed, especially before difficult itineraries. Check the brakes before going downwards.
- Permanently keep the Joëlette in balance no matter which kind of terrain you are walking on.
- The back handlebar should not be higher or lower than your waist.
- Don't continue when you are tired. Keep in mind your physical capacities should be sufficient.
- Don't walk too fast. You need to know where you put your feet and don't glide.
- Don't forget to communicate among each other, especially when the terrain is difficult.
- Beware of too big knapsacks which could get tangled up with the front arms.
- Pay attention to the passenger, especially when it is cold outside.
- Never leave a Joëlette Kid and the passenger unattended when the Joëlette Kid is on its kickstand.
- Keep in mind: usually, one doesn't fall on difficult terrain but during quiet moments when everyone loses concentration.



## Exploded view of the frame of the Joëlette Kid

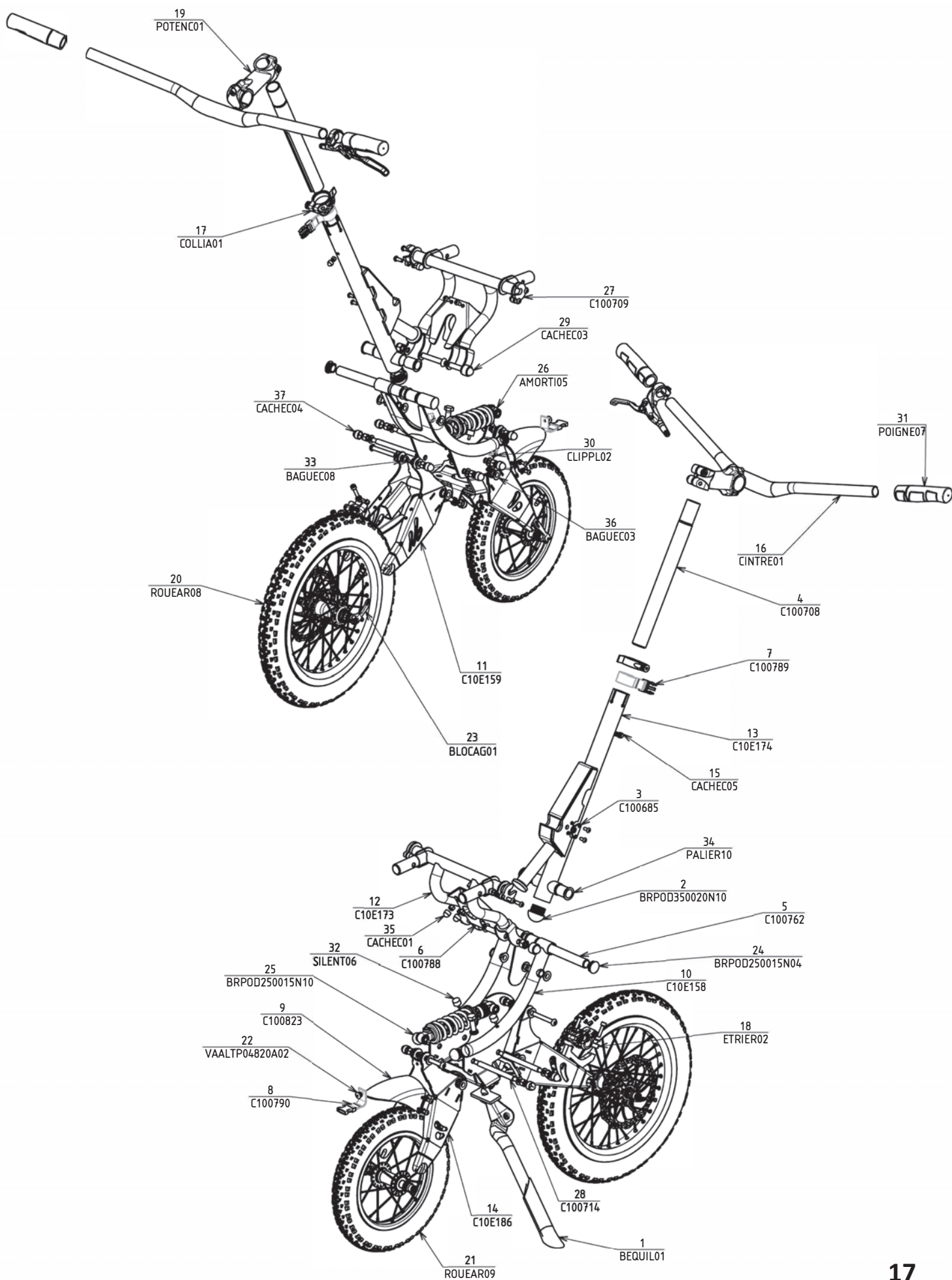

## Exploded view of the seat of the Joëlette Kid

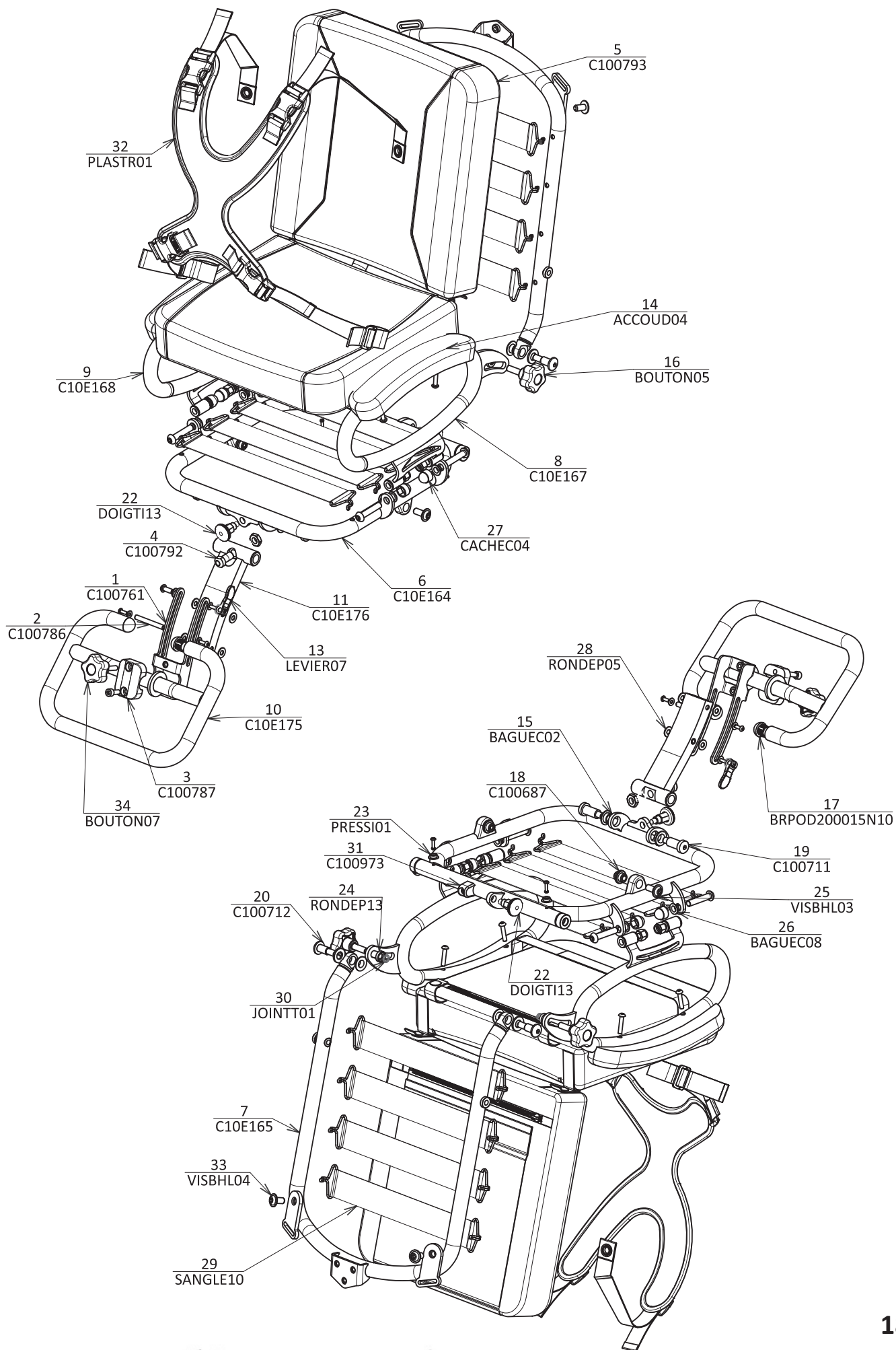

# OPTIONS



## HEADREST

Adjustable according to your child's size. Fastening system included.



## PAIR OF FRONT ARMS

Simple attachment to adapt to your Joëlette Kid in case of rough terrain, to allow a complementary companion to pull, carry the Joëlette Kid.



## UMBRELLA

Fits the Joëlette Kid on the handlebar or backrest. Several orientations are possible thanks to its flexible arm.

Stores easily in a bag during the hike.



## TRANSPORT BAGS

Bags with foams to protect the Joëlette Kid from possible shocks (customization possible).

They have a shoulder strap.

The first bag is adapted to the frame, the second to the seat and cushions (sold separately).



## MUDGUARD

Attaches to the rear wheel to prevent splashing.



### **FOOTPUMP**

To re-inflate tires in case of deflation or puncture.

### **PAIR OF ADVERTISING SUPPORTS**

To personalize your Joëlette Kid with adhesives (logos, first name, drawing, sponsors...).

### **SUPPORT FOR BOTTLE**

Water bottle holder and flocked water bottle set Joëlette And Co (sold separately).

### **REPAIR KIT**

To repair a flat tire.

# MAINTENANCE

## MAINTENANCE

The term "maintenance" means any task performed to ensure that the Joëlette Kid is in good working order and ready for use as intended. Maintenance encompasses the different areas, such as everyday care and cleaning, inspection checks, repair tasks and refurbishment.

At least once a year, you should check all technical issues of the Joëlette Kid, no matter the frequency of its utilization. When using the Joëlette Kid regularly more than once a week, a second check-up is indispensable.

The maintenance is about the same as for a mountain bike.

You should verify :

- the air pressure of the tires,
- the braking system, in particular the state of the brake pads. A «soft» brake handle does not ensure optimal braking. The lever mustn't come to a stop on the back handle until braking is at its maximum.
- the presence of security pins,
- in case of a «spongy» handle when the linings are new or in good condition, check and, if necessary, complete the brake fluid level in the brake master cylinder. The brake fluid is available in all bicycle shops.
- check the level of oil in the hydraulic system. If necessary, we can provide you a purging kit or you can contact a specialized professional.
- If you need to operate on the hydraulic braking system, especially when you change the brake pads, we can provide you a purging kit.

You will also find, in the package, red or orange plastic shims which you might want to insert between the two brake pads in case of dismounting of the wheel.

We recommend that there is always an anti-puncture tire sealant available (repair kit in option).

A bike/motorcycle repairman or a bike/motorcycle rental shop could carry out the maintenance.

## CLEANING

When cleaning the Joëlette Kid, pay attention to the following points :

- Only use a damp cloth and gentle detergent,
- Do not use any abrasive or scouring agents,
- Do not use any high-pressure cleaning devices.
- As the cover of the cushions are thermobonded, clean only the surface.

## DISINFECTION

Spray or wipe disinfection using a tested and recognized product is permitted. A list of the current permitted disinfectants is available from the Robert Koch Institute at <https://www.rki.de>

## INSPECTION CHECKS

The following table lists inspection checks that should be performed by the user and their intervals.

### Before each use of the Joëlette Kid

ITEM	INSPECTION CHECK	IF INSPECTION IS NOT PASSED
Seat locking system (indexing finger)	Make sure that the indexing finger movement is free without jamming and that the seat is locked properly.	Contact us
Tires	Check that the tires are undamaged.	Contact us or contact a cycle equipment shop.
	Check that the tires are inflated to the correct pressure	Inflate the tire to the correct pressure (see chapter "Technical data"). To repair the inner tube, contact us or contact a cycle equipment shop.
Presence of pins and safety pins	Check the presence of the safety pin of the front arms, if you have the option.	Contact us
Plastron and passenger straps.	Make sure that the locking buckle fulfils its purpose perfectly. Check that the seams or lashing karabiners are not damaged.	Contact us

## Regularly

ITEM	INSPECTION CHECK	IF INSPECTION IS NOT PASSED
All upholstered parts	Check for damage and wear, particularly on the seat cushion holding pressures, as well as the Velcro strap that holds the backrest against the frame.	Contact us
Brakes	Make sure that the brake pad wear level is not excessive.	Contact us or contact a cycle equipment shop.
	Check that the brake fluid level in the master cylinder is sufficient.	Contact a cycle equipment shop.

## LONG-TERM STORAGE

In case your Joëlette Kid is not used for a long period of time, you need to prepare it for storage to ensure a longer life for your battery (e-Joëlette).

We recommend to store the Joëlette Kid at a temperature of 15°C, avoid hot and cold extremes when storing to ensure a long service life of the product and its accessories.

Store in dry, well-ventilated environment protected from outer influences.

Slightly overinflate pneumatic tires.

## AFTER USE

### DISPOSAL

- The equipment wrapping is potentially recyclable.
- The metal parts are used for scrap metal recycling.
- The plastic parts are used for plastic recycling.
- Disposal must be carried out in accordance with the respective national legal provisions.

## TECHNICAL DATA

The technical information provided hereafter applies to a standard configuration of the Joëlette Kid.

These can change if accessories are added.

Note that in some cases the measured values may vary up to  $\pm 10$  mm.

<b>PERMISSIBLE OPERATING AND STORAGE CONDITIONS</b>	
Temperature range for operation	from -25°C to +50°C
Recommended storage temperature	15°C

<b>BACK TIRE</b>	
Tire type	16" x 1.9"
Tire pressure	The recommended maximum tire pressure in bar or kpa is marked on the side wall of the tire. If more than one value is listed, the lower one in the corresponding units applies.

<b>FRONT TIRE</b>	
Tire type	12" x 1.9"
Tire pressure	The recommended maximum tire pressure in bar or kpa is marked on the side wall of the tire. If more than one value is listed, the lower one in the corresponding units applies.



## Dimensions

	<b>KID (WITHOUT HEADREST, BACK HANDLE AT ITS LOWEST POSITION)</b>
Total height	1031 mm
Total width	620 mm
Total length	860 mm
Seat height	715 mm
Seat width	330 mm
Seat depth	270 mm
Min. seat thickness	50 mm
Backrest height	350 mm
Min backrest thickness	50 mm
Backrest angle	90° à 110°
Seat angle	6°
Armrest height	130 mm
Armrest length	225 mm
Distance footrest - seat	de 180 mm à 300 mm
Ground clearance	400 mm
Frame storage dimensions	737(L) x 528(W) x 290(H) mm
Seat storage dimensions (without cushions)	490(L) x 372(W) x 110(H) mm
Interface storage dimensions	318(L) x 315(W) x 125(H) mm

<b>WEIGHT</b>			
	<b>Frame</b>	<b>Seat (without headrest, with cushions)</b>	<b>Interface</b>
<b>Weight</b>	8.2 kg	4 kg	1.8 kg

<b>KID + SEAT</b>	
<b>Charge maxi</b>	<b>25 Kg</b>

# UNFOLDING THE JOËLETTE KID (WITH THE SEAT)



1. Unfold the kickstand. Position the chassis on its wheels. Detach the strap at the front, then straighten the stem until you hear the «click». Check that the frame is properly locked.



2. Unlock the handle clamp and insert the handlebar into the stem, then lock the clamp.

3. Take the seat and fold the footrest forward.

**TIGHTEN THE CLAMP FIRMLY ENOUGH TO PREVENT THE HANDLE FROM SLIPPING WHEN CARRYING THE BIKE.**



4. Put the seat in the frame fork.



5. Tilt the seat in the print on the frame at the back with the indexing pin pulled.



6. Fold the armrests on the sides of the seat and straighten the backrest.



7. Pull up the armrests to screw them on the backrest with the rollers, while you adjust its inclination.

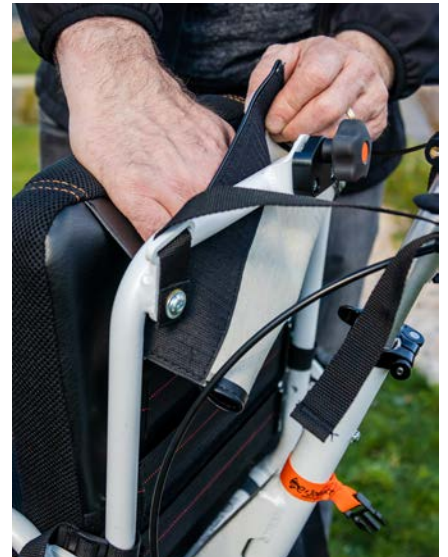

8. Place the cushions on the seat. Attach the snap fasteners of the straps to the back of the seat on the frame of the Joëlette Kid. Fix the backrest cushion by running the fabric lining behind the backrest and fasten the velcro.

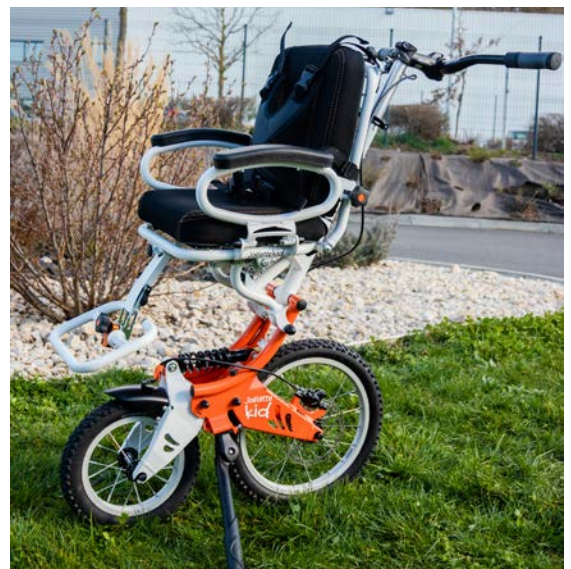

9. Adjust the position of the back handle for a better comfort of use.

Your Joëlette Kid is ready to use !

**To fold the Joëlette Kid, proceed the other way round.**

**To unlock the frame of the seat, proceed as shows in the following picture.**



A video is available on our website and our Youtube channel.



# INSTALLATION OF THE HEADREST ON THE SEAT (EN OPTION)

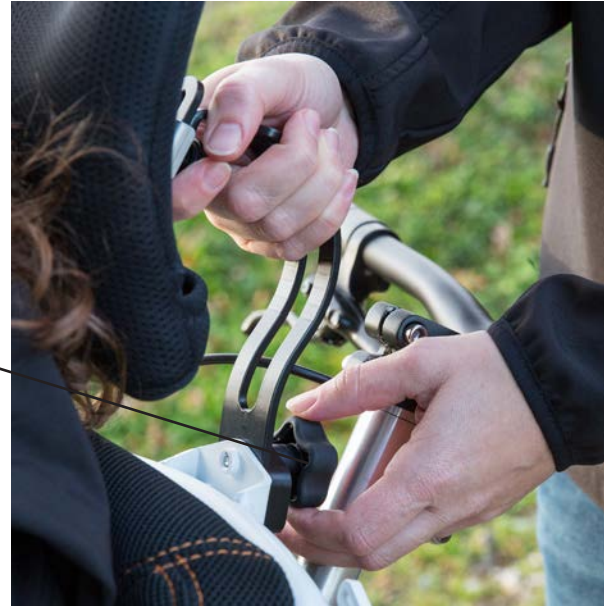

1. Insert the headrest support between the backrest and the plastic part and secure it using the roller.



2. Adjust the height thanks to the roller in the back of the headrest.



3. Adjust the tilt of the headrest by turning it to the desired angle.



# INSTALLATION OF THE FRONT ARMS



1. Insert the arm on the tube provided for this purpose under the seat.



2. Align the holes in both tubes to put the security pin.



3. Insert the security pin and fold the rounded metal part over the tube to secure the fastener. Check that the arms are securely fixed.

# SHOCK ABSORBER ADJUSTMENT



You can adjust the hardness of the shock absorber of your Joëlette Kid thanks to the nut located at the back of the spring, but also its speed of rebound with the roller on the front part.



## STORAGE OF THE JOËLETTE IN ITS BAGS (IN OPTION)



1 – Place the frame inside the bag, then put the back handlebar on the wheels (tube upwards).

2 – In the second bag, place the folded seat and the cushions.

**Warning:** when you fold and store the Joëlette Kid, make sure you don't pinch the hydraulic brake cables.

The cable cross-section is not covered by the warranty.

# CONTACT

**DON'T HESITATE TO CONTACT THE TEAM OF  
JOËLETTE AND CO FOR ANY OTHER QUESTION**



[export@joëletteandco.com](mailto:export@joëletteandco.com)



0033 (0)4 - 77 - 42 - 62 – 58

Join the Joëlette's Community on the social networks !



**@FERRIOL-MATRAT – ALL RIGHTS RESERVED**

*This manual is protected by the law of 11 March 1957 on literary and artistic property, supplemented by the law of 3 July 1985 and by all copyright agreements. In accordance with these laws and conventions, no reproduction, total or partial copying of the manual, programs or systems is authorized without the prior written consent of FERRIOL-MATRAT. FERRIOL-MATRAT reserves the right to revise and improve these products. This publication describes the status of the product at the time of publication and does not prejudice any changes it may undergo.*